



Pilous

Železná 9, 619 00 Brno, Czech Republic

Tel.: +420 543 25 20 10

e-mail: metal@pilous.cz, www.pilous.cz

ARG 130

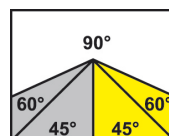

1730 x 13 x 0,65

	90°	+45°	+60°
●	130	115	70
■	130	105	60
■	180 x 100	115 x 75	70 x 60

Main motor	230 V, 50 Hz, 0,55 kW / 400 V, 50 Hz, 0,37/0,55 kW
Pump motor	230 V, 50 Hz, 0,065 kW / 400 V, 50 Hz, 0,05 kW
Saw blade speed	75 m/min. / 40/80 m/min.
Working height of vice (with base)	905 mm
Coolant tank	cca 15 l
Machine dimensions (min.)	450 x 950 x 550 mm
Machine dimensions (max.)	830 x 1100 x 1538 mm
Machine weight	70 / 77 / 99 kg

DESCRIPTION

A universal “small” band saw is appraised for general use in various workshops (work on locks, maintenance), at plants with machinery and in field installations. Robust framework of the machine is made of grey cast iron. The feed into cut is manual, against the pressure of the spring.

- Modern concept of the band saw arm allows for large cutting ranges in both upright and angular cutting.
- Continuous adjustment of the cutting angle within the range 90°–60° when the workpiece is clamped tight.
- Simple locking and adjusting of the desired cutting angle on the angle scale.
- Maximum cutting accuracy and saw band service life in this category of band saws.
- High-precision three-side hardmetal band saw guidance.
- Manufactured bearing of running wheels, tensioning wheel system and all rotary parts are the same as in big professional machines.
- Professional, noiseless and maintenance-free band drive is provided by an industrial electric motor with worm gearbox.
- The machine can be equipped with two types of motors.
- Single-phase motor (230 V) with universal saw band speed of 75 m/min. facilitates easy mains connection. Three-phase two-speed motor (400 V) with saw band speed of 40 and 80 m/min. is suitable for frequent cutting of full sections and thick-walled sections.
- The machine is equipped with a 250 mm workpiece stop.

ARG 130 band saws are manufactured in the following versions:

ARG 130

Bench band saw without cooling.

ARG 130 TK

Bench band saw with cooling. The machine is connected to a complete cooling system with a professional high-performance pump and possibility of regulating the flow on both guiding heads.

ARG 130 K

Band saw with a base and cooling. The machine is connected to a complete cooling system with a professional high-performance pump and possibility of regulating the flow on both guiding heads. Coolant tank is placed in the base of the machine. This version allows you to install conveyors both before and after the cut.

PHOTOGALLERY





Workpiece stop - Standard equipment

Simple stop for setting the required length of the material to be cut.

DR105/130/200/235*

CONVEYORS

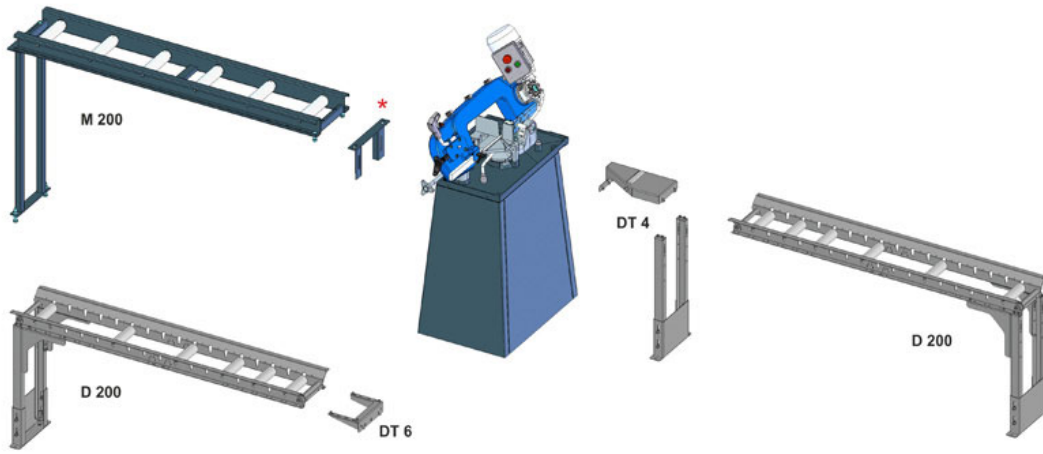

*) Is always a part of the conveyor. Note: M200 cannot be attached as output conveyor.



- Original bandsaw blades produced using the latest technology with top-quality German materials, while strictly complying with all stated production and control procedures.
- High productivity and precision of cut with the maximum service life of the blade is ensured.
- Wide range of produced types of sawblades and tooling enables the professional cutting of almost all available materials.

Bi-metal blade
Consists of bearing band from special steel on which a layer of HSS material is welded into where the teeth are milled.

Constant toothting
The distance of the teeth are always the same.

Variable toothting
The distance of teeth vary and is periodically repeated. This results in a greater cutting range, ability to further eliminate vibrations caused by the impact of the tooth blade on material, longer service life of the blade.

M42

Universal blade recommended for a wide palette of material, including tool steels and stainless steel up to hardness 45 HRC. Teeth are made from steel HSS-M42 containing cobalt.

M51

Blade for tool and stainless steel with hardness up to 50 HRC. Tooth tips are made from steel HSS-M42 containing cobalt and wolfram

Carbide

Consists of bearing band from special steel into which the teeth are milled on which especially grinded carbide plates are welded. The carbide mounted blade is recommended for cutting surface hardened materials, chrome parts, forged pieces and materials with external tenacity and hardness up to 62 HRC.

Cutting range

For optimal output of the blade, the correct selection of the size of the blade tooth is important depending on the size of the divided material.



Variable toothting		Constant toothting		Variable toothting		Constant toothting	
a(D) [mm]		a(D) [mm]		t [mm]		t [mm]	
0-25	10/14	0-10	18	0-4	10/14	0-1	18
20-40	8/12 (8/11)	5-20	14	3-6	8/12 (8/11)	0-3	14
30-60	6/10	20-40	10	6-9	6/10	4-7	10
40-70	5/8 (5/7)	40-80	6	9-13	5/8 (5/7)	8-11	6
60-110	4/6	80-120	4	12-16	4/6	12-15	4
80-140	3/4	120-200	3	16-22	3/4	16-20	3
120-350	2/3	200-400	2	20-35	2/3	21-30	2
250-550	1,4-2	300-800	1,25	30-85	1,4-2	31-90	1,25
380-750	1/1,5			40-85	1/1,5		
550-3000	0,75/1,25			80-200	0,75-1,25		

When selecting the number of teeth for the blade, the general principle applies of a minimum of 4 teeth, but no more than 30 teeth are in contact with the work piece.

Be careful when unpacking welded saw blades. They are in a shipping container in tensioned condition. Remove the saw blade cover only after fitting it onto the machine.



COOLcut Opti

COOLcut Opti – universal coolant and lubricant. Such machining fluid allows achievement of unique lubricating and cooling properties during the machining process.

- low aromatic, highly refined mineral oil
- effective corrosion inhibitors provide permanent protection of the workpiece and the machine from corrosion
- above average stability and excellent wettability ensure excellent cooling and lubricating effect even in very hard water
- minimum tendency to foaming ensures effective lubrication
- high efficiency and profitability of use
- long-term biostability

In addition to use in saw bands the product is designed for machining operations carried out both on conventional machines and NC and CNC machining centres. Recommended concentration 4–7 %. 1 and 5 litres pack. Dilution 1:20.



COOLcut Eco 65

COOLcut Eco 65 – universal cooling and lubricating emulsifying oil, well biodegradable according to OECD 301-D test. Biodegradability of 65 % in 21 days.

- Such machining fluid allows achievement of unique lubricating and cooling properties during the machining process
- highly refined synthetic ester oil
- effective corrosion inhibitors provide permanent protection of the workpiece and the machine from corrosion
- above average stability and excellent wettability ensure excellent cooling and lubricating effect even in very hard water
- minimum tendency to foaming ensures effective lubrication
- high efficiency and profitability of use
- long-term biostability

In addition to use in saw bands the product is designed for machining operations carried out both on conventional machines and NC and CNC machining centres. Recommended concentration 4–7 %. 5 litres pack. Dilution 1:20.



COOLcut Bio 90

COOLcut Bio 90 – universal cooling and lubricating emulsifying oil, well biodegradable according to OECD 301-D test. Biodegradability of 90 % in 21 days. Due to its biodegradability it can be used in any outdoor environment without environmental damage.

- Such machining fluid allows achievement of unique lubricating and cooling properties during the machining process
- highly refined synthetic ester oil
- effective corrosion inhibitors provide permanent protection of the workpiece and the machine from corrosion
- above average stability and excellent wettability ensure excellent cooling and lubricating effect even in very hard water
- minimum tendency to foaming ensures effective lubrication
- high efficiency and profitability of use
- long-term biostability

In addition to use in saw bands the product is designed for machining operations carried out both on conventional machines and NC and CNC machining centres. Recommended concentration 4–7 %. 5 litres pack. Dilution 1:20.



COOLcut Micro

COOLcut Micro – an easily biodegradable semi-synthetic cooling and lubricating micro-emulsion. Due to its biodegradability it can be used in any outdoor environment without environmental damage. Such machining fluid allows achievement of unique lubricating and cooling properties during the machining process.

- highly refined synthetic ester oil
- effective corrosion inhibitors provide permanent protection of the workpiece and the machine from corrosion
- above average stability and excellent wettability ensure excellent cooling and lubricating effect even in very hard water
- minimum tendency to foaming ensures effective lubrication
- high efficiency and profitability of use
- long-term biostability

In addition to use in saw bands the product is designed for machining operations carried out both on conventional machines and NC and CNC machining centres. Recommended concentration 4–7 %. 5 litres pack. Dilution 1:20.



COOLcut Antifreeze

COOLcut Antifreeze – low-freezing ingredient for water miscible coolants used in winter in outdoors environment, up to minus 20 °C, depending on the dosage.

- effectively lowers the freezing point of the fluid
- very good resistance to oxidation guarantees long service life
- does not act aggressively on the sealing elements (elastomers), to which it comes into contact.

5 litres pack. Dilution 1:20.

Optima Antifreeze	(%)	10	20	30	40	50
Flowability temperature	(°C)	-5	-10	-17	-26	-40

RECOMMEND



OH 90

Simple and very fast deburring of all kinds of sections (including the internal edges) or full material by a rotary steel brush. High quality construction of the machine along with a three-phase motor make use of the machine possible in specialized workshops as well as in production plants. Compared to manual deburring it reduces the required time and hence reduces your costs. While maintaining incomparably higher and balanced quality of deburring.

We recommend using stainless steel brush for stainless steel products.
Example of the difference between manual deburring (including internal edges) and OH 90

Hollow section 60 x 60 x 2 mm:	manual deburring - 32 s	machine OH 90 - 8 s
Tube diameter 50 x 2 mm:	manual deburring - 21 s	machine OH 90 - 4 s



OHE 90

Simple and very fast deburring of all kinds of sections (including the internal edges) or full material by a rotary steel brush. High quality construction of the machine along with a three-phase motor make use of the machine possible in specialized workshops as well as in production plants. Compared to manual deburring it reduces the required time and hence reduces your costs. While maintaining incomparably higher and balanced quality of deburring.

We recommend using stainless steel brush for stainless steel products.
Example of the difference between manual deburring (including internal edges) and OH 90

Hollow section 60 x 60 x 2 mm:	manual deburring - 32 s	machine OH 90 - 8 s
Tube diameter 50 x 2 mm:	manual deburring - 21 s	machine OH 90 - 4 s