

UKB-SYSTEEM L

TYPE LVD

Informatie	114 – 115
Bovengereedschappen	
78° Bovengereedschappen	116
26° Bovengereedschap	116
Houder voor uitwisselbare buiglijsten 86°/84°/28°	117
Houder voor radiusgereedschappen R 7,0-50,0	117
Houders voor Z-buiggereedschappen Z 1,0-15,0	118
Dichtdrukgereedschap	118
Ondergereedschappen	
78° Ondergereedschappen, H = 90 mm	119 – 120
78° Ondergereedschap, H = 130 mm	120
30° Ondergereedschappen, H = 90 mm	121
Multi-V ondergereedschappen	122
Bovengereedschap adapters	123
Ondergereedschap adapters	123
Monteren van een opspanlip	123



04







WWW.UKB-GMBH.NL

Type LVD

VOORDELEN

- Optimale materialen
 - 42 CrMo4, veredeld tot 1100-1200 N/mm²
 - 1.2312, veredeld tot 950-1100 N/mm²
 - C45, veredeld tot 800-850 N/mm²
 - C45
- Buigradii/inloopradii gehard tot 52-55 HRC = -----
- Nauwkeurig geslepen = √
- Gegarandeerde uitwisselbaarheid
- Parallelliteit
- Ondergereedschappen door middel van adapters op alle andere kantpersen toepasbaar (zie hoofdstuk 10)
- Markering van het gereedschap met belangrijke informatie

UKB-LEVERTIJD

-  *Op voorraad*
-  *Aanpassing 1 – 3 werkdagen*
-  *1 – 2 werkweken*
-  *Op aanvraag*

Verdere informatie m.b.t. **bereikbaarheid, leveringservice en betalingscondities** zie omslag!

Standaard:

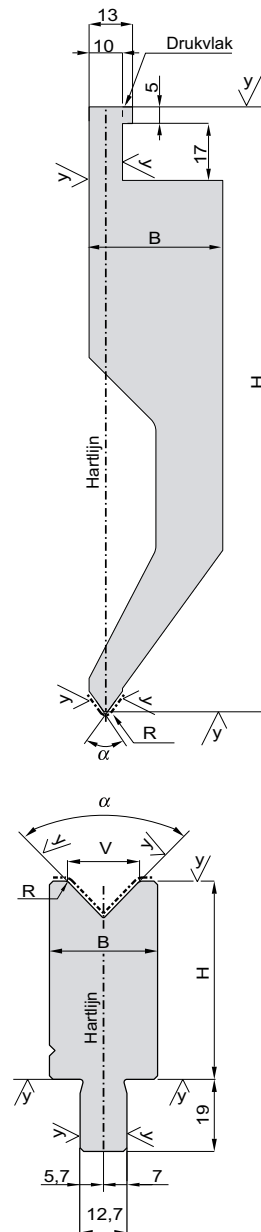

Overige opnamen:

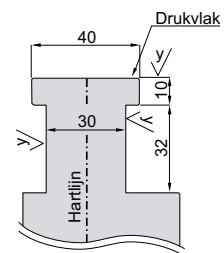
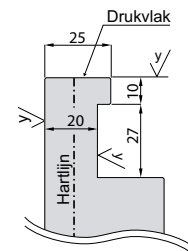
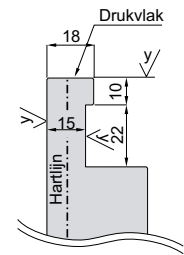

Hielstukken

- Hielstukken voor gedeelde bovengereedschappen UKB-Systeem L

Hielstuk

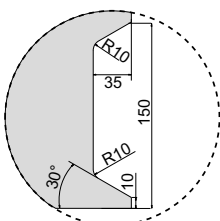

UKB-AANPASSING

Maak gebruik van onze flexibele aanpassingen binnen 1 - 3 werkdagen!

Voor verdere informatie zie hoofdstuk 13 of op www.ukb-gmbh.nl



Gereedschapslengtes

Bovengereedschappen

Lengte 508 mm



Lengte 550 mm gedeeld

- Gedeelde bovengereedschappen worden uitsluitend als complete set geleverd
- 10 deelstukken

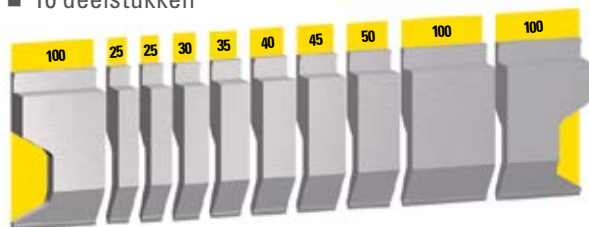

Ondergereedschappen

Lengte 508 mm



Lengte 550 mm gedeeld

- Gedeelde ondergereedschappen worden uitsluitend als complete set geleverd
- 9 deelstukken

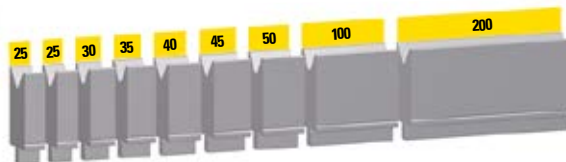

UKB-BEREIKBAARHEID

Maandag t/m vrijdag van 7:30 tot 18:00 uur

Tel: +49 (0) 27 36 / 44 42 - 0

Fax: +49 (0) 27 36 / 44 42 - 22

E-mail: post@ukb-gmbh.nl

Internet: www.ukb-gmbh.nl

Voor uw persoonlijke contactgegevens,
zie bijlage. Steeds tot uw dienst!

WWW.UKB-GMBH.NL

Online winkel > Actuele prijzen en speciale aanbiedingen

Nieuwe ontwikkelingen > Altijd op de hoogte

Productinformatie > Alle UKB producten in één oogopslag

Downloads > Nuttige informatie

Video kanaal > Inzicht in ons bedrijf en
interessante productvideo's

UKB-APP

Perskrachtberekening > Automatische perskrachtberekening m.b.v. uw gegevens

Productinformatie > Alle UKB producten in één oogopslag



78° Bovengereedschappen

16.500

508 mm	380,- €	17,7 kg
550 mm gedeeld	626,- €	19,2 kg

1-2
werktoon

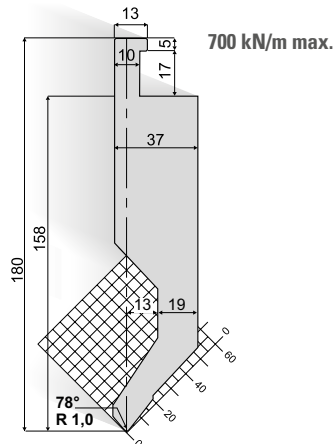

16.510

508 mm	406,- €	16,8 kg
550 mm gedeeld	658,- €	18,2 kg

1-2
werktoon

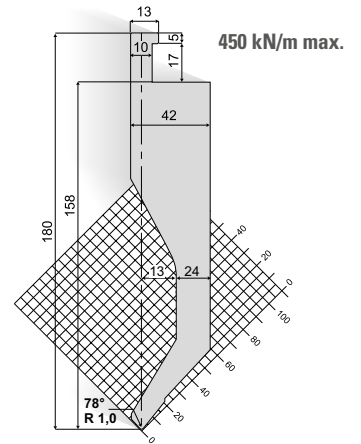

16.520

508 mm	296,- €	11,5 kg
550 mm gedeeld	532,- €	12,4 kg

1-2
werktoon

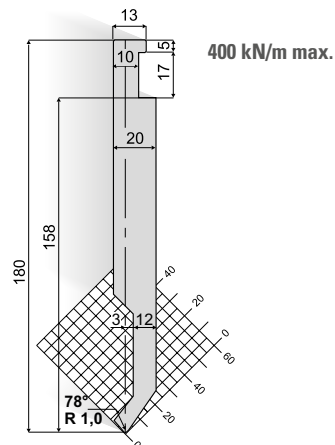

16.540

508 mm	254,- €	9,1 kg
550 mm gedeeld	480,- €	9,8 kg

1-2
werktoon

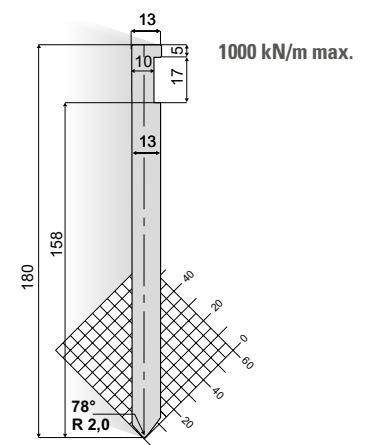

26° Bovengereedschap

16.530

508 mm	274,- €	8,0 kg
550 mm gedeeld	500,- €	8,7 kg

1-2
werktoon

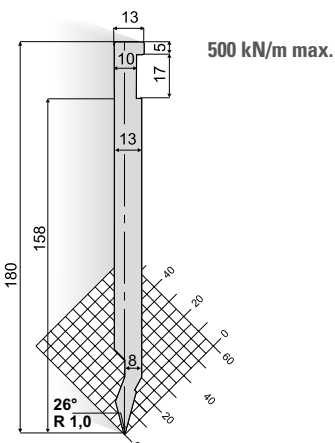

UKB-INFO

Meer opnames van UKB-Systeem L
zie pagina 114

Houder voor uitwisselbare buiglijsten 86°/84°/28°

VOORDELEN

- Eenvoudig in het gebruik
- Lage kosten: één houder voor verschillende buiglijsten
- Snel en eenvoudig wisselen van de buiglijsten

16.070

500 mm	390,- €	12,5 kg
300 mm	314,- €	7,5 kg
200 mm	216,- €	5,0 kg
100 mm	118,- €	2,5 kg
550 mm gedeeld	812,- €	13,8 kg

Houder voor buiglijsten met gehard oplegvlak

1-2 verfoeken

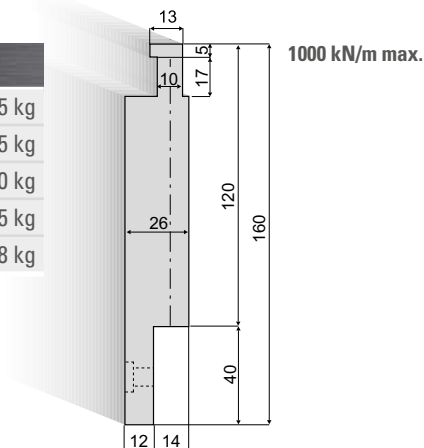

MONTAGEVOORBEELD

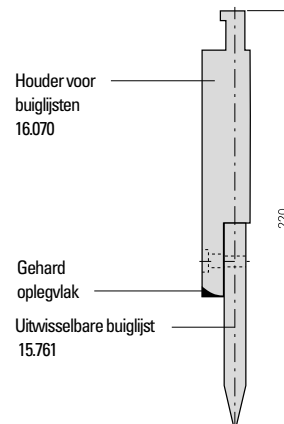

UKB-INFO

Bijbehorende buiglijsten zie pagina 24

04

Houder voor radiusgereedschappen R 7,0-50,0

VOORDELEN

- Eenvoudig in het gebruik
- Instellen overbodig bij R 12,5-50,0
- Zeer stabiel
- Flexibel inzetbaar d.m.v. uitwisselbare radiusgereedschappen
- Gedeelde radiusgereedschappen op aanvraag

16.010

830 mm	390,- €	18,0 kg
412 mm	224,- €	9,0 kg

Houder voor radiusgereedschappen

1-2 verfoeken

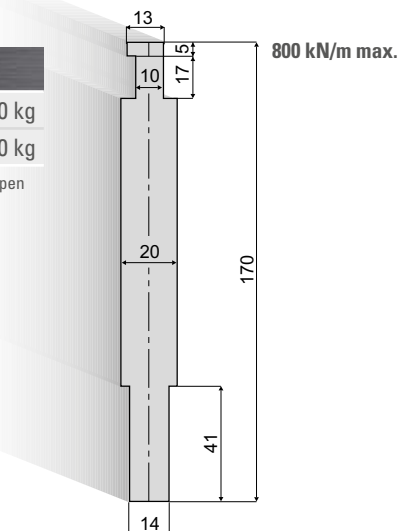

MONTAGEVOORBEELD

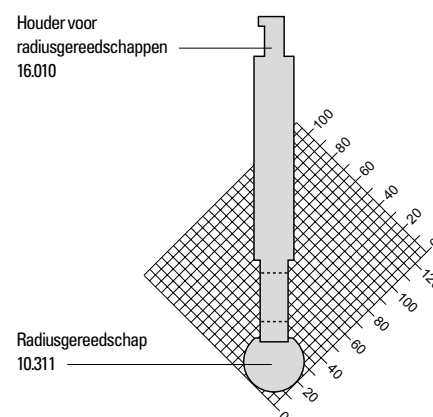

UKB-INFO

Bijbehorende radiusgereedschappen zie pagina 31

VIDEO

Radiusgereedschappen



Houders voor Z-buiggereedschappen Z 1,0-15,0

VOORDELEN

- Flexibel inzetbaar d.m.v. uitwisselbare Z-buiggereedschappen Z 1,0-15,0
- Eenvoudig in het gebruik
- Instellen overbodig
- Zeer stabiel
- Kleine Z-lengte in één bewerking te zetten
- Z-buigingen met lange beenlengtes mogelijk
- Gedeelde Z-buiggereedschappen op aanvraag

16.050

835 mm	1.134,-€	73,4 kg
415 mm	626,-€	36,7 kg

Houders voor Z-buiggereedschappen worden uitsluitend als complete set geleverd



16.060

835 mm	1.275,-€	60,0 kg
415 mm	665,-€	30,0 kg

Houders voor Z-buiggereedschappen worden uitsluitend als complete set geleverd

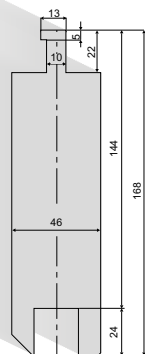

1000 kN/m max.

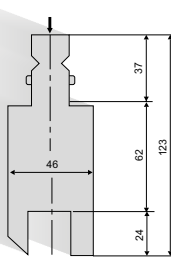

1000 kN/m max.

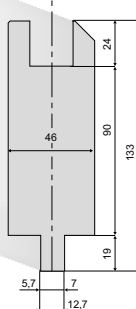
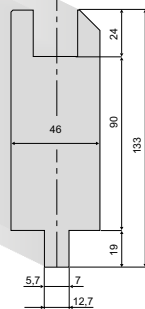

MONTAGEVOORBEELD

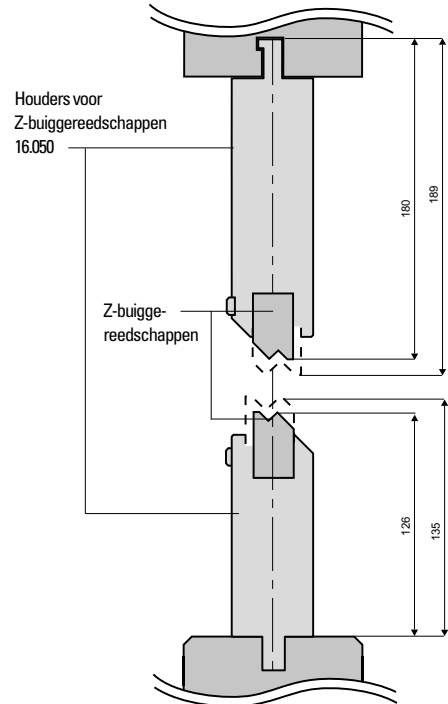

Z-buiggereedschappen worden d.m.v. M8 klembouten in de houder gemonteerd.

UKB-INFO

Bijbehorende Z-buiggereedschappen zie pagina 27

VIDEO

Z-buiggereedschappen



Dichtdrukgereedschap

Dichtdrukgereedschap

Model	835 mm		415 mm	
	Prijs	Gewicht	Prijs	Gewicht
40.500	256,-€	10,0 kg	144,-€	5,0 kg

Dichtdrukgereedschap wordt uitsluitend als complete set geleverd

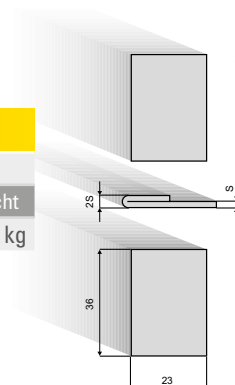

1000 kN/m max.

UKB-INFO

Perskracht tabel voor dichtdrukken zie pagina 52

78° Ondergereedschappen, H = 90 mm

26.706

508 mm	244,- €	6,5 kg
550 mm gedeeld	466,- €	7,0 kg

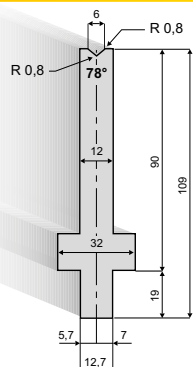

400 kN/m max.

26.708

508 mm	244,- €	6,5 kg
550 mm gedeeld	466,- €	7,0 kg

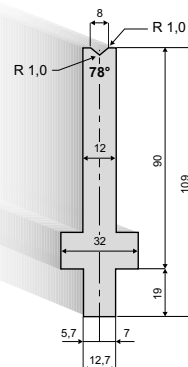

400 kN/m max.

26.710

508 mm	244,- €	7,0 kg
550 mm gedeeld	466,- €	7,6 kg

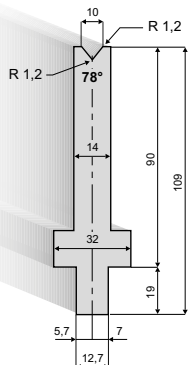

500 kN/m max.

26.712

508 mm	244,- €	8,0 kg
550 mm gedeeld	466,- €	8,7 kg

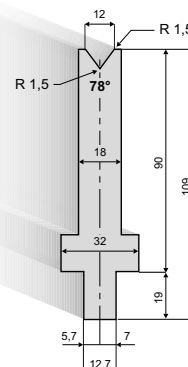

600 kN/m max.

26.716

508 mm	232,- €	10,0 kg
550 mm gedeeld	454,- €	10,8 kg

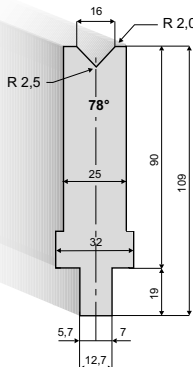

800 kN/m max.

26.720

508 mm	232,- €	12,0 kg
550 mm gedeeld	454,- €	13,0 kg

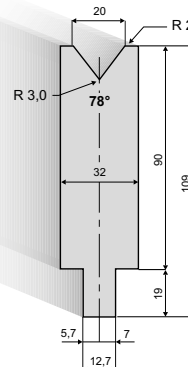

800 kN/m max.

26.724

508 mm	232,- €	11,7 kg
550 mm gedeeld	454,- €	12,7 kg

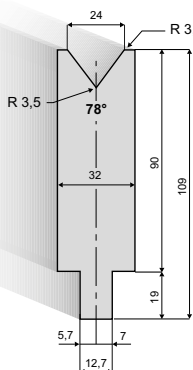

1000 kN/m max.

26.730

508 mm	250,- €	14,2 kg
550 mm gedeeld	504,- €	15,4 kg

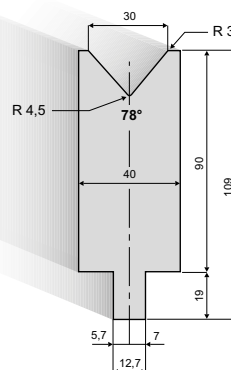

1000 kN/m max.

78° Ondergereedschappen, H = 90 mm

26.740

508 mm	276,- €	17,3 kg
550 mm gedeeld	562,- €	18,4 kg

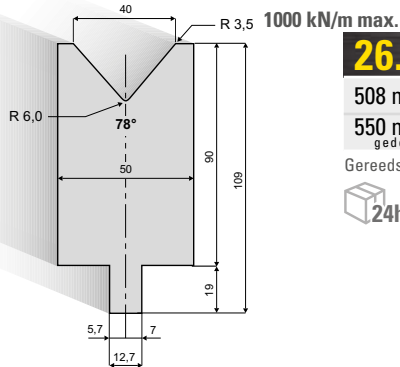

26.750

508 mm	360,- €	23,0 kg
550 mm gedeeld	694,- €	24,9 kg

Gereedschap is hoger belastbaar

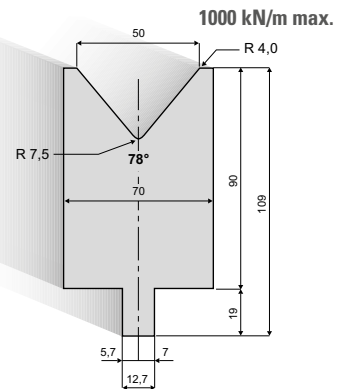

26.760

508 mm	370,- €	21,5 kg
550 mm gedeeld	704,- €	23,3 kg

Gereedschap is hoger belastbaar

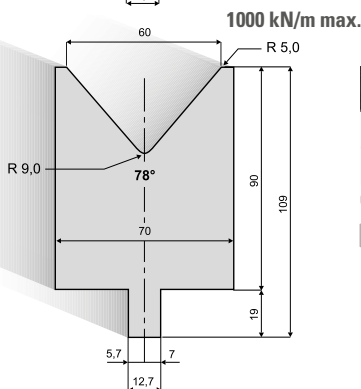

26.780

508 mm	422,- €	27,0 kg
550 mm gedeeld	826,- €	29,2 kg

Gereedschap is hoger belastbaar

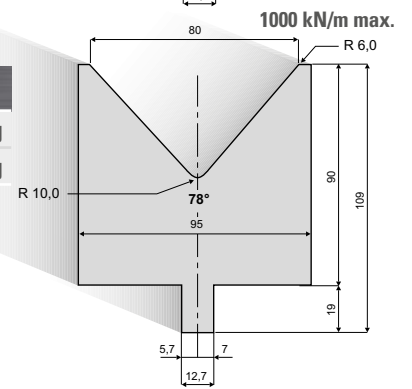

26.794

508 mm	514,- €	31,5 kg
550 mm gedeeld	992,- €	34,1 kg

Gereedschap is hoger belastbaar

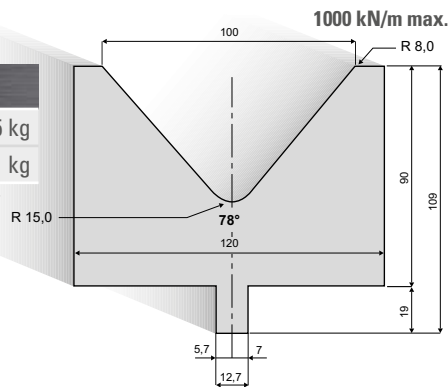

78° Ondergereedschap, H = 130 mm

26.797

508 mm	768,- €	56,0 kg
550 mm gedeeld	1.418,- €	60,6 kg

Gereedschap is hoger belastbaar

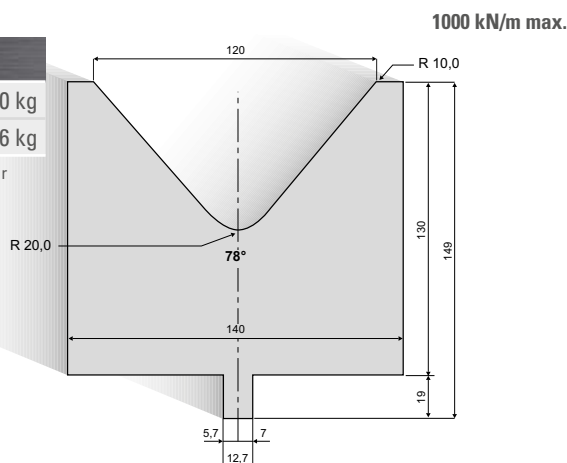

UKB-REPARATIE- EN NASLIJPSERVICE

Maak gebruik van onze reparatie- en naslijpservice voor versleten kantpersgereedschappen en schaarmessen! Voor verdere informatie zie hoofdstuk 14 of op www.ukb-gmbh.nl

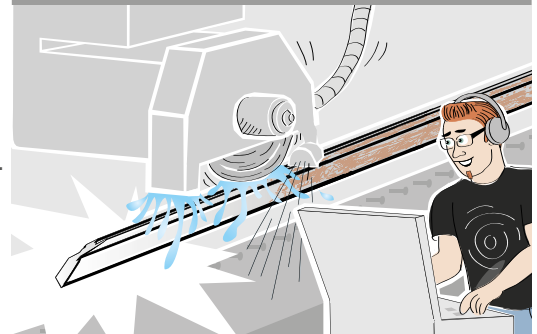

30° Ondergereedschappen, H = 90 mm

26.306

508 mm	272,- €	7,5 kg
550 mm gedeeld	504,- €	8,1 kg

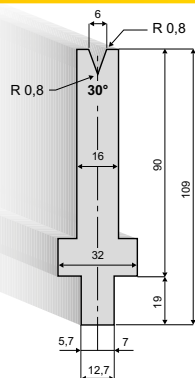

400 kN/m max.

26.308

508 mm	272,- €	8,0 kg
550 mm gedeeld	504,- €	8,7 kg

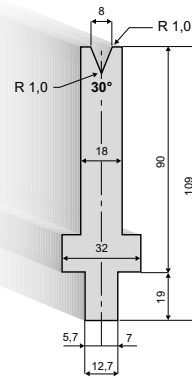

350 kN/m max.

26.310

508 mm	260,- €	10,0 kg
550 mm gedeeld	492,- €	10,8 kg

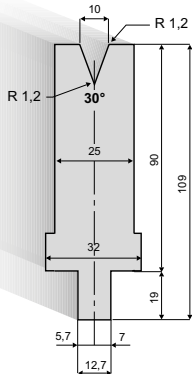

400 kN/m max.

26.312

508 mm	260,- €	9,5 kg
550 mm gedeeld	492,- €	10,3 kg

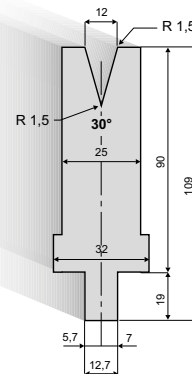

400 kN/m max.

26.316

508 mm	292,- €	14,3 kg
550 mm gedeeld	552,- €	15,5 kg

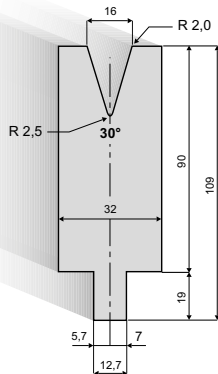

500 kN/m max.

26.320

508 mm	304,- €	13,8 kg
550 mm gedeeld	564,- €	14,9 kg

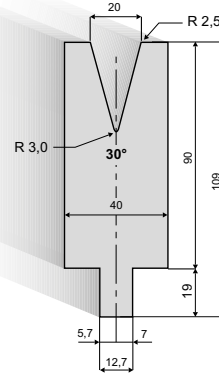

600 kN/m max.

26.324

508 mm	334,- €	15,0 kg
550 mm gedeeld	628,- €	16,2 kg

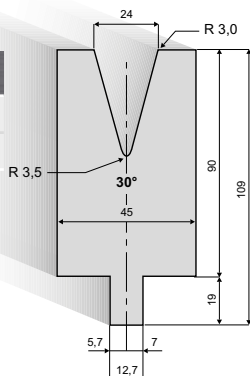

600 kN/m max.

UKB-INFO

Bij kalibreren/dooddrukken in 30° ondergereedschappen vermindert de belastbaarheid met 50% van de opgegeven waarde.

Multi-V ondergereedschappen

26.070

Lengte naar wens
maakbaar

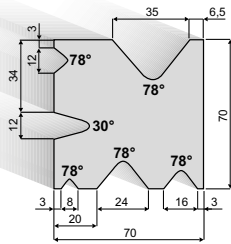

26.090

Lengte naar wens
maakbaar

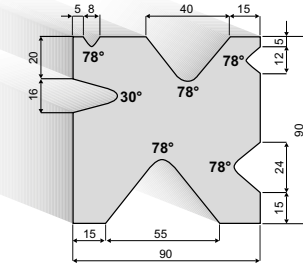

26.130

Lengte naar wens
maakbaar

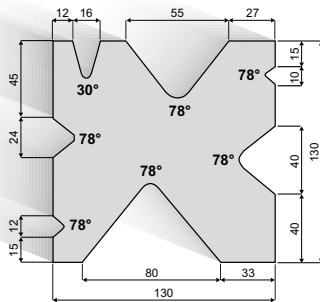

26.180

Lengte naar wens
maakbaar

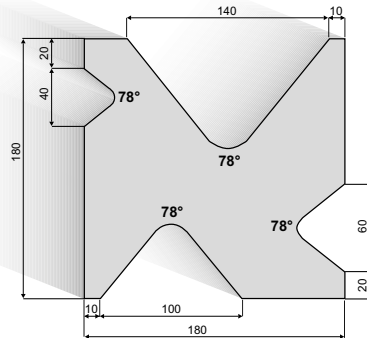

Bovengereedschap adapters

50.990

150 mm 92,- € 3,0 kg

UKB-Systeem L → UKB-Systeem A
Noodzakelijke klemplaat zie pagina 203

24h

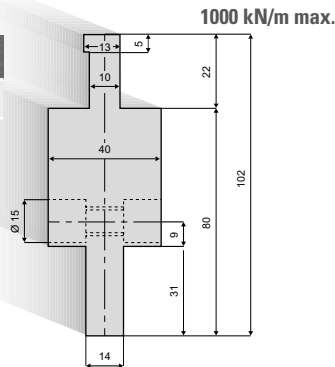

MONTAGEVOORBEELD

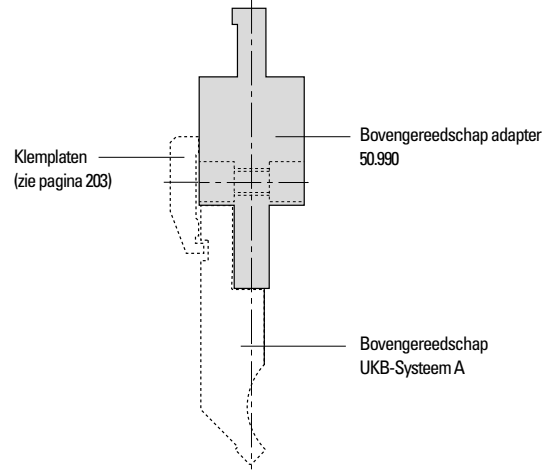

50.470

150 mm 300,- € 3,8 kg

UKB-Systeem L → UKB-Systeem B
Incl. klemlijst

1-2 werken

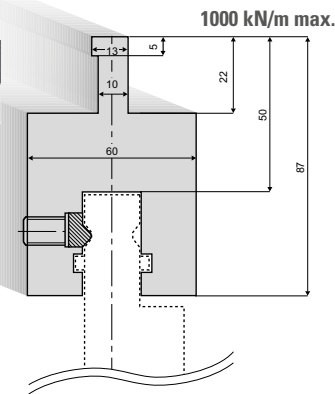

Aantal benodigde adapters

(Onderlinge montage afstand ca. 50 mm)

Lengte van de kantpers (mm)	Aantal (stuks)
835	4
1.250	6
2.100	10
2.600	13
3.100	15
4.100	20

Ondergereedschap adapters

60.930

835 mm 284,- € 25,0 kg
415 mm 172,- € 12,5 kg

UKB-Systeem L → UKB-Systeem A

24h

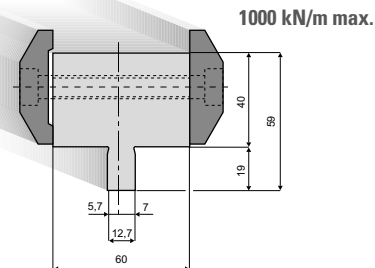

60.935

1000 mm 378,- € 11,0 kg
500 mm 208,- € 5,5 kg

UKB-Systeem L → UKB-Systeem B/C

24h

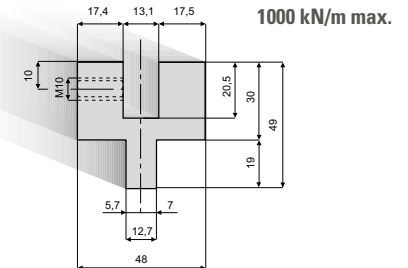

Monteren van een opspanlip

MONTAGEVOORBEELD

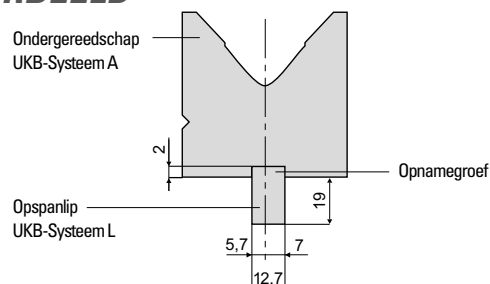

D.m.v. het frezen van een 2 mm diepe opnamegroef en het monteren van een geslepen opspanlip (12,7 x 21 mm) kunnen ondergereedschappen UKB-Systeem A ook op kantpersen UKB-Systeem L worden toegepast. Prijzen zie pagina 248.